

N/A	N/A	IS1018	INSTRUCTION SHEET				
N/A	N/A	61100526	KIT, SPRING				
N/A	N/A	6V100205	KIT, SEAL, FKM				
N/A	N/A	60100205	KIT, SEAL, STANDARD				
35	2	39V53002	WIPER,PRESS-IN, (1-1/4)	X	X		X
34	1	39H52034	SEAL,T, (1-7/8X1/8X2-1/8)	X	39V52042		X
33	1	39H52033	SEAL, BEVEL, 1 7/8 X 1/8 X 2 1/8	X	39V52041		
32	1	39H51002	O-RING, (-033)	X	39V51002		
31	1	39F54011	BU RING,(-225)	X	X		
30	1	91000033	ASSY, RPS, WS, DA, CGS, 5500				
29	1	91000032	ASSY, SHUTTLE, WS, DA, CGS, RPS, 5500				
28	1	81071005	HOUSING, RPS, WS, DA, CGS, 5500				
27	1	81071004	CAP, BODY, WS, DA, CGS, 5500				
26	1	81071003	CAP, HOUSING, WS, DA, CGS, RPS				
25	1	81042004	STUD, WS, DA, CGS, 5500 X 1/2 STRK				X
24	1	81040609	BOLT, CONTACT, WS, DA, CGS, 5500				X
23	1	81000813	BODY, WS, DA, CGS, TF, RPS, 5500				
22	1	70643770	VALVE, PRESSURE RELIEF, 1 PSI				
21	3	39055011	SEAL, BONDED, M3	X	X		
20	1	39054017	BU RING,(-033)	X	X		
19	1	39051069	O-RING, (61mm x 1.5)	X	39V51069		
18	1	39051068	O-RING, (51mm x 1.5)	X	39V51068		
17	1	39051066	O-RING, (-016)	X	39V51066		X
16	3	39051025	O-RING, (-011)	X	X		
15	1	39000026	O-RING, (-906)	X	39V00037	X	X
14	2	30603322	PLUG, PIPE, HEX, HOL, 1/8 NPT, STEEL				
13	2	30601144	PLUG, SOCH, SAE 4				
12	4	23600002	BALL, STEEL, ALLOY, .250				X
11	1	23530000	PIN, SPRING, COIL TYPE, 3/32 X 3/8, SST				
10	1	23355008	SPRING, COMPRESSION			X	
9	1	23350065	SPRING, COMPRESSION			X	X
8	1	23311016	SPRING, COMPRESSION			X	X
7	3	21500019	SCREW, CAP, BTNH, M3 X 6, ALY				
6	1	21430037	WASHER				X
5	1	21430033	WASHER				
4	1	21430022	WASHER				X
3	3	21411035	SCREW, CAP, SOCH, 10-32 X 5/8, ALY				
2	10	21411034	SCREW, CAP, SOCH, 1/4-28 X 5/8, ALY				
1	1	21411033	SCREW, CAP, SOCH, 5/16-24 X 1/2, ALY, SLFLKGG				X

No.	QTY	PART No.	DESCRIPTION	STANDARD SEAL KIT	FKM SEAL KIT	SPRING KIT	INCLUDED IN SUB-ASM 91-0000-32
-----	-----	----------	-------------	-------------------	--------------	------------	--------------------------------

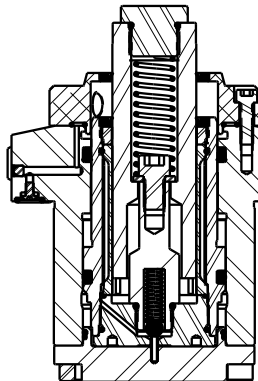

SEE IS1018 FOR SERVICE INSTRUCTIONS

LUBRICATE ALL SEALS WITH CLEAN HYDRAULIC OIL PRIOR TO ASSEMBLY

DO NOT USE SILICONE BASED LUBRICANTS

**PARTS LIST**





VEKTEK, INC.  
1334 E. SIXTH AVE. P.O. BOX 625  
EMPORIA, KS. 66801 U.S.A.

B	2785	RELEASE	MAJ	1-12-15
REV	IN ACCORDANCE WITH ECN	EFFECTIVE DATE	REVISED BY	DATE
DRW BY: ALUTHI	<b>DRAWING STATUS: Released</b>			
DATE: 8-12-10	PRODUCTION APPROVED FOR RELEASED STATUS ONLY			

ASSEMBLIES AFFECTED	PARTS LIST, ASSY, WS, DA, CGS, TF, RPS, 5500
10-0212-01	*****
10-0212-01F	
SIZE A	PL1079
REV B	

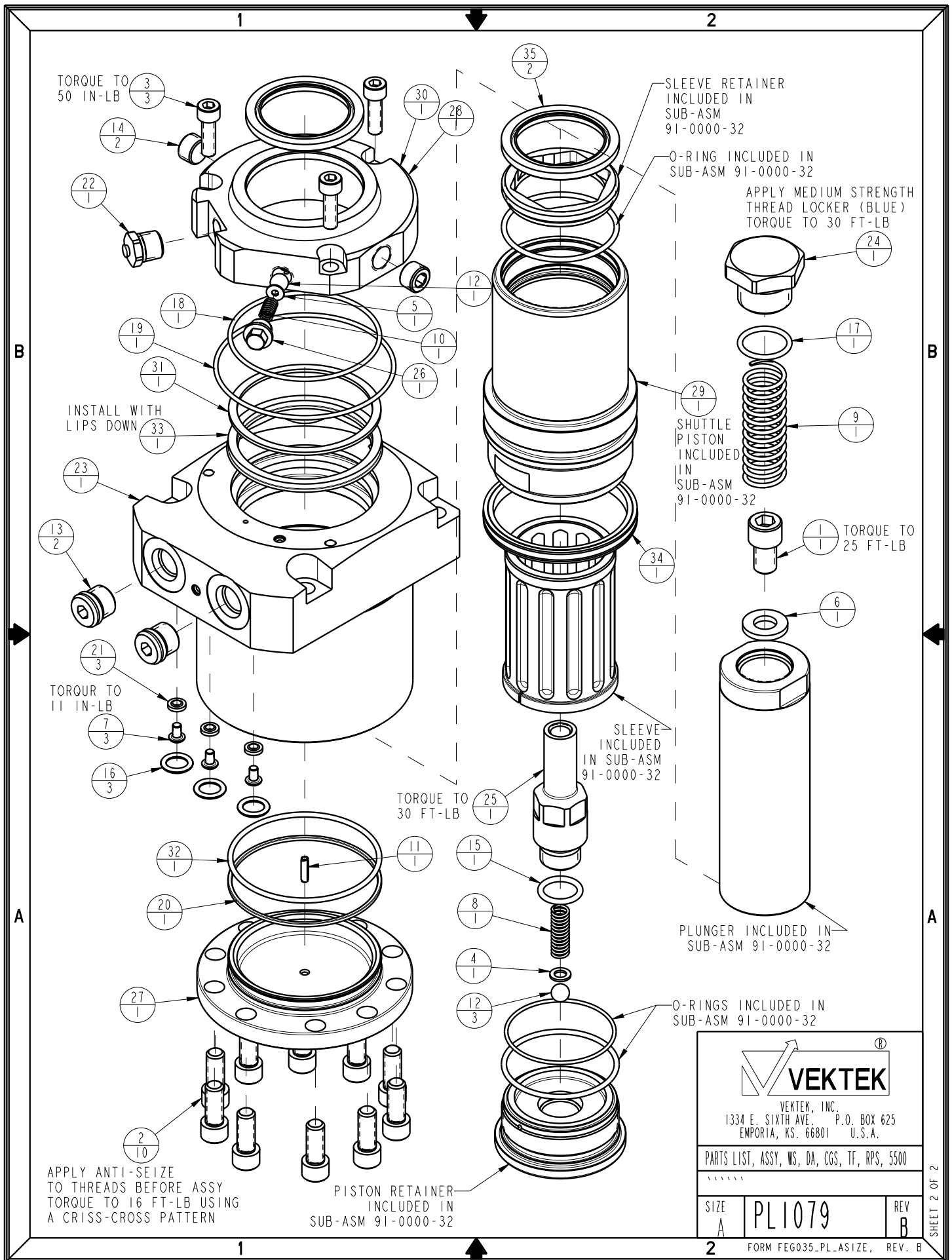
FORM FEG035\_PL\_ASIZE, REV. B



 <b>VEKTEK</b> VEKTEK, INC. 1334 E. SIXTH AVE. P.O. BOX 625 EMPORIA, KS. 66801 U.S.A.		
PARTS LIST, ASSY, WS, DA, CGS, TF, RPS, 5500		
SIZE A	PL1079	REV B
FORM FEG035_PL_ASIZE, REV. B		

SHEET 2 OF 2

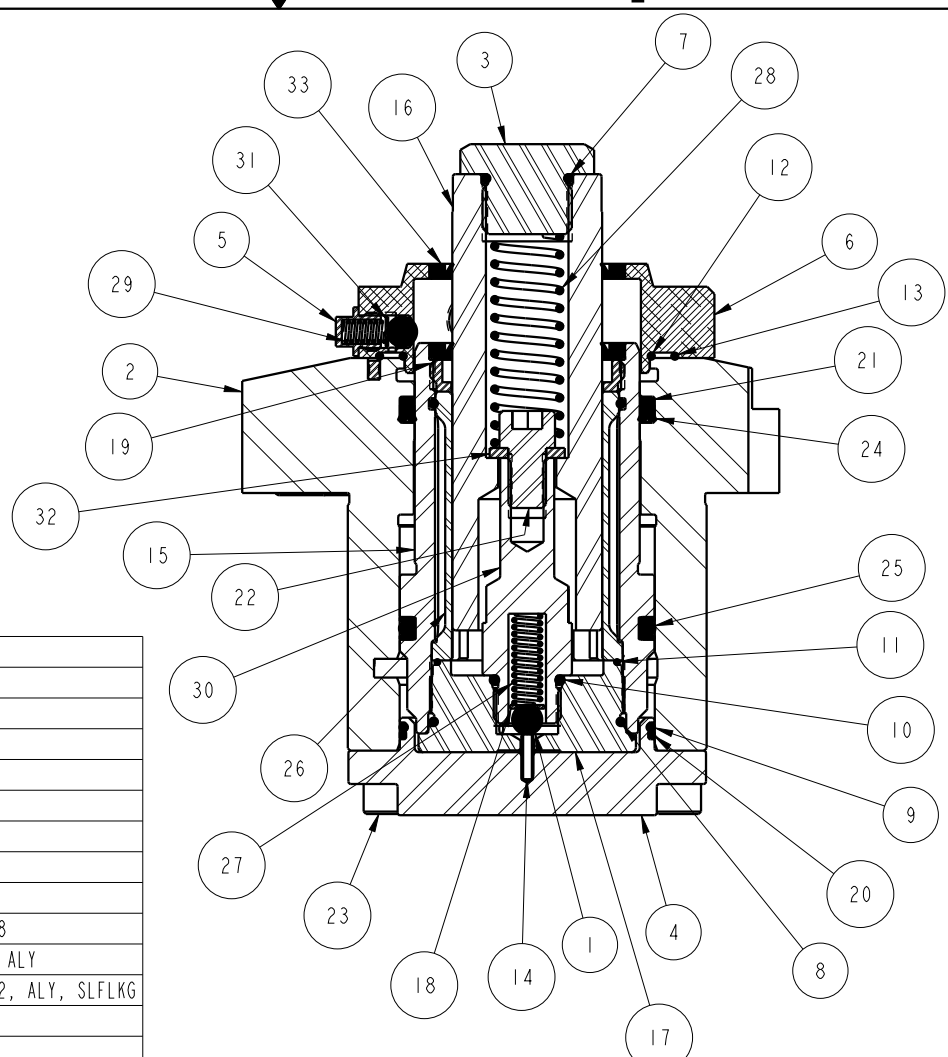

33	WIPER,PRESS-IN, (1-1/4)
32	WASHER
31	WASHER
30	STUD, WS, DA, CGS, 5500
29	SPRING, COMPRESSION
28	SPRING, COMPRESSION
27	SPRING, COMPRESSION
26	SLEEVE, WS, DA, CGS, 5500
25	SEAL,T, (1-7/8X1/8X2-1/8)
24	SEAL, BEVEL, 1 7/8 X 1/8 X 2 1/8
23	SCREW, CAP, SOCH, 1/4-28 X 5/8, ALY
22	SCREW, CAP, SOCH, 5/16-24 X 1/2, ALY, SLFLKG
21	BU RING, (-225)
20	BU RING, (-033)
19	RETAINER, SLEEVE, WS, DA, CGS, 5500
18	WASHER
17	RETAINER, PISTON, WS, DA, CGS, 5500
16	PLUNGER, WS, DA, CGS, RPS, 5500
15	PISTON, SHUTTLE, WS, DA, CGS, 5500
14	PIN, SPRING, COIL TYPE, 3/32 X 3/8, SST
13	O-RING, (61mm x 1.5)
12	O-RING, (51mm x 1.5)
11	O-RING, (5-142)
10	O-RING, (-906)
9	O-RING, (-033)
8	O-RING, (-029)
7	O-RING, (-016)
6	HOUSING, RPS, WS, DA, CGS, 5500
5	CAP, HOUSING, WS, DA, CGS, RPS
4	CAP, BODY, WS, DA, CGS, 5500
3	BOLT, CONTACT, WS, DA, CGS, 5500
2	BODY, WS, DA, CGS, TF, RPS, 5500
1	BALL, STEEL, ALLOY, .250
No.	DESCRIPTION

MODEL NUMBER	TOOL LIST
10-0212-01 10-0212-01F	7/16, 1 & 1 1/8 wrenches 5/32, 3/16 & 1/4 hex key 1/4 socket, 11/16 deep well socket

<b>INSTALLATION INSTRUCTIONS</b>	 <b>VEKTEK</b> <small>VEKTEK, INC.          1334 E. SIXTH AVE. P.O. BOX 625          EMPORIA, KS. 66801 U.S.A.</small>
	<b>INSTRUCTION SHEET, WS, DA, CGS, TF, RPS, 5500</b> ***** SIZE <b>1S1018</b> REV <b>B</b>

B	2785	RELEASE	MAJ	1-26-15
REV	IN ACCORDANCE WITH ECN	EFFECTIVE DATE	REVISED BY	DATE
DRW BY:	ALUTHI	<b>DRAWING STATUS: Released</b> PRODUCTION APPROVED FOR RELEASED STATUS ONLY		
DATE:	8-12-10			

ASSEMBLIES AFFECTED
10-0212-01
10-0212-01F

SIZE	<b>1S1018</b>	REV	<b>B</b>
------	---------------	-----	----------

READ ALL INSTRUCTIONS BEFORE DISASSEMBLY

REFER TO THE ILLUSTRATION ON PAGE ONE FOR COMPONENT NUMBERS AND TOOL LIST

## DISASSEMBLY

1. Remove return position sensor housing (6) using 5/32" hex key to remove the 3 SHCS. Remove the housing cap (5) using 1/4" socket and remove spring (29), washer (31) and ball (1). Remove o-rings (12) and (13) and press out wiper (33).
2. Clamp work support body (2) in vise and using 3/16" hex key remove SHCS (24) from bottom cap (4). Remove bottom cap (4) from body (2) and remove o-ring (9) and back-up ring (20).
3. Slide shuttle piston (15) sub-assembly out of body (2). Remove back-up ring (21), and bevel seal (22) from body (2). Remove T-seal (23) from shuttle piston (15).
4. Using 1" and 1 1/8" wrenches remove contact bolt (3) from plunger (16), remove spring (28) and o-ring (7).
5. Clamp shuttle piston (15) in vise clamping on the flats near the bottom. Remove SHCS (25) and washer (32), plunger can now be removed.
6. Using 11/16" deep well socket remove stud (30) from piston retainer (17) and remove o-ring (10) from stud. Remove spring (27), washer (18), and ball (1).
7. Using small flat blade screw driver, remove wiper (33) from shuttle piston (15). CAUTION: DO NOT DAMAGE INSIDE OF SLEEVE (26) OR SLEEVE RETAINER (19).
8. DO NOT REMOVE SLEEVE RETAINER (19) OR PISTON RETAINER (17) FROM SHUTTLE PISTON (15). DOING SO WILL VOID PRODUCT WARRANTY!
9. Clean all parts thoroughly and set aside to dry.

## ASSEMBLY

1. Lubricate o-rings (7), (9), (10), (12) & (13), T-seal (23), bevel seal (22) and back-up rings (20) & (21) with clean hydraulic oil (Vektek 65-0010-01 or equivalent). Apply Loctite® primer N or equivalent to the threads of contact bolt (3), then allow to dry.
2. Install ball (1), washer (18), spring (27) into piston retainer (17) through top of shuttle piston (15). Install o-ring (10) on SAE 6 boss of stud (30). Torque stud into piston retainer, 30 ft-lb.
3. Press wiper (33) into top of shuttle piston (15) using only enough force to seat wiper into counterbore. CAUTION: EXCESS FORCE MAY CAUSE DAMAGE TO WIPER.
4. Slide plunger (16) into sleeve (26). Install washer (32) and SHCS (25), torque to 25 ft-lb. Install spring (28) into plunger (16). Install o-ring (7) onto contact bolt (3) and apply medium strength Loctite® (blue) to threads. Thread contact bolt (3) into plunger (16) and torque to 30 ft-lb. Plunger should freely move up and down in sleeve without binding or dragging. Spring force should return plunger to full stroke without sticking.
5. Install T-seal (23) onto shuttle piston (15) with round bulb facing out. Install back-up rings on each side of T-seal bulb. Make sure back-up rings are seated.
6. Install bevel seal (22) into body (2) with lips facing piston bore, push to bottom of groove, then install back-up ring (21). Make sure seals are not rolled.
7. Slide shuttle piston (15) subassembly into body (2) bore. Shuttle piston should slide smoothly up and down in bore.
8. Install back-up ring (20) and o-ring (9) onto cap (4). Install cap (4) into body (2) with holes in proper orientation. Apply anti-seize to threads of SHCS (24), insert through cap and thread into body. Torque to 16 ft-lb using a criss-cross pattern.
9. Press wiper (33) into top of return position sensor housing (6). Install ball (1), washer (31) and spring (29) into housing (6). Install housing cap (5) and tighten. Install o-rings (12) and (13) onto bottom side of housing (6). Install housing sub-asm onto body (2), insert SHCS and torque to 50 in-lb.

		
VEKTEK, INC. 1334 E. SIXTH AVE. P.O. BOX 625 EMPORIA, KS. 66801 U.S.A.		
INSTRUCTION SHEET, WS, DA, CGS, TF, RPS, 5500 *****		
SIZE A	IS1018	REV B
FORM FEG035_PL_ASIZE, REV. B		